

Flat Pattern view
SCALE: 1:2

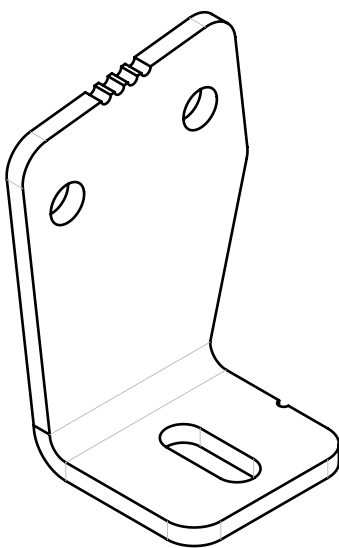
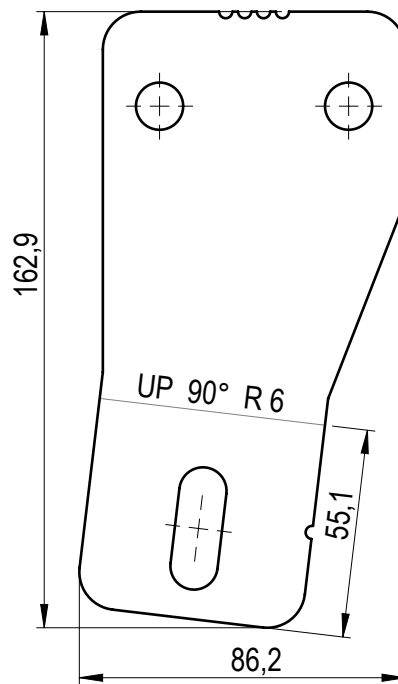
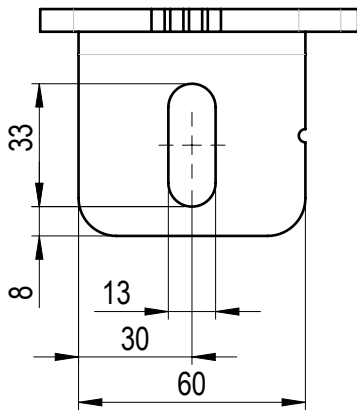

Other dimensions from .DXF file.

SHEET METAL INFORMATION	
Length, mm	164
Width, mm	81.7
Thickness, mm	6
Inside Bend Radius, mm	6
K-Factor	0.5
No. of Bends	1

	MATERIAL		WEIGHT		DEBURR AND BREAK SHARP EDGES		REVISION	DATE	
	S355J2		0.489 Kg		DO NOT SCALE DRAWING			28.05.2025	
SURFACE PROTECTION		MACHINING		THERMAL CUTTING		WELDING		SCALE	FORMAT
HDG EN ISO 1461		ISO 2768 mK		ISO 9013 221		ISO 13920 BF		1:2	A4
NAME		SIGNATURE		PART NO.					
Designed by D. Dislers				105-09100-40					
Drawn by D. Dislers				DESCRIPTION				SHEET 1/1	
Technical ref.				Left bracket 7M					